

MADE in the USA

Quality Does Matter

Our Dealers Serve:

- Telephone Utilities
- Power Utilities
- Cable Companies
- National Laboratories
- Municipalities
- Contractors
- Government Agencies
- Fleet Safety
- Oil and Gas
- Healthcare
- Fire Departments
- Police (State & Local)
- *****

- Complete Line of Replacement Parts
- Mobile Power Trailers
- Mobile HVAC
- Standby Power Trailers
- Solar Arrowboard Trailers
- Fiber Optic Splicing Trailers
- Satellite Communications
- Mobile Restoration Trailers
- Air Reclamation Trailers
- Police & Fire Respond Units
- Custom Truck Packages



1 800-883-3639

www.teamfenex.com



**A Division of
Synergy Power Group, LLC**

We thank you so much for your interest in TEAM FENEX's products and services!

The TEAM FENEX name is proudly displayed on thousands of quality mobile products since our beginnings in the early 1990's. Our American constructed products are convenient work centers, easily deployed, and are designed for specific duties in supporting maintenance and construction activities in the hostile environments found in the power and gas utility, cable, military and telecommunications industries.



Moving from its humble beginnings in Centralia, Illinois, TEAM FENEX constructed its first production facility on our current location in Sandoval, Illinois in 1997. Growth came at an astounding rate, as our product's quality and serviceability was recognized and then specified by the nation's largest telephone companies. By the year 2000, we were ranked as # 117 among America's fastest growing companies, by Inc. 500 magazine. In 2001, one of the nation's leading corporations, Leggett and Platt, Inc. acquired us in order to provide mobile power capabilities to enhance their portfolio.

Continuing the emphasis on quality in our manufacturing systems, led us in 2001 to seek and be awarded ISO certification. This quality manufacturing recognition assures our ever important customer base that key processes are documented to industry standards and monitored on a very specific and rigid basis. We believe and insist that our products and processes are reviewed carefully and are continually improved.



In 2003, we expanded our product mix by designing and producing custom truck equipment. This equipment provides "plug and play" ease of installation for truck up-fitters, both regional and national. It offers work center components comparable to those in our mobile trailer packages and can be easily installed into their truck bodies. In consideration of our customers whose work requires them to be in confined spaces, we offer air conditioning in our mobile trailer packages and truck packages. This is a welcome relief and improvement to personnel safety.

In 2005 we became part of Leggett and Platt's newly formed division "Commercial Vehicle Products (CVP)" and In 2011 we extended the facility which in turn doubled our manufacturing space. We consider it room to exceed your expectations for equipment, shipped on time, with extreme quality, and backed by the best customer service available in the industry today.



In April of 2013, five managers at TEAM FENEX banded together to form Synergy Power Group, LLC, purchasing TEAM FENEX from Leggett & Platt. Thus changing the culture back to a small town family oriented mentality.

Synergy Power Group LLC and its founders are dedicated to bringing you the highest quality products at the best possible prices, now and in the future.

We ask you to page through this new catalog; reach out to our sales department and let us provide solutions for your maintenance and construction requirements.

With our TEAM's deepest respect,

TEAM FENEX

A Division of Synergy Power Group, LLC



For A Better Tomorrow!

Equipment

Product	Series	Page
MPU Standard	Mobile Power Units	2-3
MPU 2-Ton A.C	Mobile Power Units	4-5
MPU 5-Ton A.C	Mobile Power Units	6-7
FOST 7X12	Fiber Optic Splicing Trailer	8-9
FOST 6X10	Fiber Optic Splicing Trailer	10-11
FOST 6X8 CUB	Fiber Optic Splicing Trailer	12-13
FOST Truck	Fiber Optic Splicing Truck	14
SATCOM	Satellite Communications Trailer	15
Delivery System - Compressor	Delivery Systems	16
Delivery System - Air Conditioning	Delivery Systems	17
Delivery System - Air Conditioning/ Heat	Delivery Systems	18
Delivery System - Gensets	Delivery Systems	19
The PLAT	Power, Light & Air Trailer	20-21
15 & 25 Light Models	Trailer Mounted Arrowboard	22-23
10-18kW Models	Standby Generator Trailers	24
25-100kW Models	Standby Generator Trailers	25
Mobile Transformer Trailer	Mobile Transformer Trailer	26-27
DRT	Disaster Relief Trailer	28-29
Air Reclamation Trailer	Air Reclamation Trailer	30
John Deere Products	John Deere Powered Trailers	31
Agricultural Solutions	John Deere Powered Trailers	32
Oil/Gas/Fracking	John Deere Powered Trailers	33

Parts & Accessories

1.1 HP Submersible Pump	Dewatering Pumps	36
2.0 HP Submersible Pump	Dewatering Pumps	36
12VDC Submersible Pump	Dewatering Pumps	35
Aluminum Anti- Sludge Pump Stand	Dewatering Pumps	37
Aluminum Extension Planks	Manhole Safety	40
Anti-theft Wheel Boot	Wheel Stability	56
Belt-Driven Air Compressor	Air Compressor & Components	49
Brake Actuator	Other Accessories	57
Centrifugal Pump	Dewatering Pumps	35
Delivery System Control Panel	Control Panels	50
Diesel Engine Start/Stop Control Panel	Control Panels	52
Discharge Hose Options	Hose Options	38
Dry & Tool Air Hose Reel Assembly	Air Compressor & Components	48
Dual Floodlight & Strobe Assembly	Safety Lighting	43
Fiber Optic Cable Clamp	Other Accessories	60
Fiber Optic Splice Trailer Control Panel	Control Panels	51
Floodlight & Strobe Assembly	Safety Lighting	42
Gasoline Engine Start/Stop Control Panel	Control Panels	52
Heater Element- 6000 Watt	Other Accessories	57
Heatless Air Dryer	Air Compressor & Components	47
HUBBELL Connects	Electrical Equipment	44
Jib Crane Control Cord	Electrical Equipment	45
Light Standard Assembly & Flood light	Safety Lighting	43
Lunette Eye- 2 1/2"	Other Accessories	58
Lunette Eye- 3" Adjustable	Other Accessories	58
Magnet Base Quartz Floodlight	Safety Lighting	42
Manhole Platform Support	Manhole Safety	41
Manhole Safety Ring	Manhole Safety	39
Manhole Steel Guard Rail	Manhole Safety	39
Mobile Power Unit Control Panel	Control Panels	50
Moisture Alarm	Air Compressor & Components	47
Nitrogen Bottle Replacement System	Air Compressor & Components	48
Oil-less Air Compressor	Air Compressor & Components	49
Propane Aluminum Tank	Fuel Equipment	53
Propane Bottle Warmer	Fuel Equipment	54
Propane Hose & Valve Kit	Fuel Equipment	54
Propane Steel Tank	Fuel Equipment	53
Propane Tank Bracket Assembly	Fuel Equipment	54
Remote Control Cord Reel	Electrical Equipment	46
Safety Tow Chains	Other Accessories	60
Standby Generator Control Panel	Control Panels	51
Steel A-Frame Gantry Material Lift	Manhole Safety	41
Stem with Wheel & Caster	Wheel Stability	55
Strainer Assembly	Dewatering Pumps	37
Suction Hose Options	Hose Options	38
Tongue Jack Dual Wheel	Wheel Stability	55
Tongue Jack Single Wheel	Wheel Stability	55
Trailer Lighting Cord	Electrical Equipment	45
Wheel Chock Assembly- Rubber	Other Accessories	59
Wheel Chock Assembly- Steel	Other Accessories	59



MPU

Proudly Made in the USA



Quality Trailer Construction:

- Heavy-duty welded frame
- Powder-coated, galvanized steel panels.
- Stainless steel hardware
- Trailer is load balanced



*Built to handle the daily
hostile environment of
underground utility work!*



2-TON A.C. MPU

Proudly Made in the USA



Quality Trailer Construction:

- Heavy-duty welded frame
- Powder-coated, galvanized steel panels.
- Stainless steel hardware
- Trailer is load balanced
- Mobile climate control providing ventilation & de-humidification



*Built to handle the daily
hostile environment of
underground utility work!*





2-Ton MPU Series Options

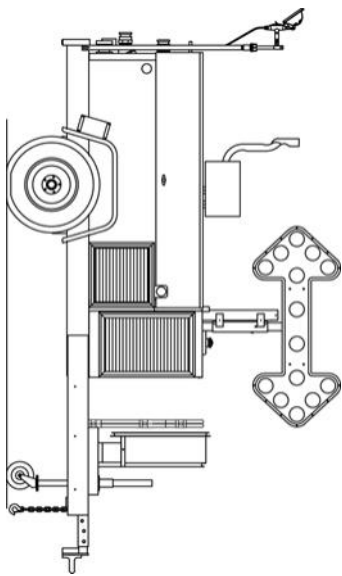

All Trailers Include:

- Control Box
- 3" Lunette Eye
- Taillight Connector
- 5/16"X34" Safety Chains with Hooks
- Landing Jack with Steel Wheel
- Rubber Wheel Chocks
- Interior Compartment Light
- Safety Tape Package
- Safety Cone Storage
- 2-Ton Air Conditioner
- Blower Hose 8"X25'
- Electric Brakes

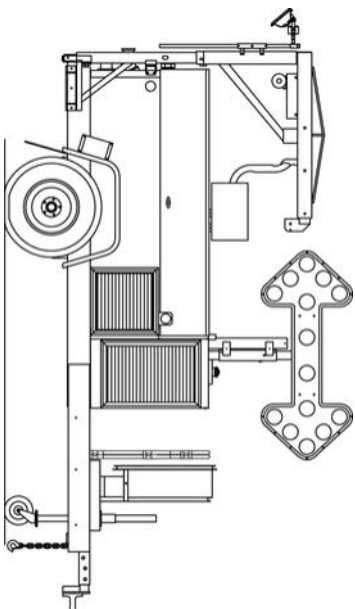

UNIT MODEL	2-TON MPU			POWER								
	Base131KG2	Silver131KG2	Gold131KG2	Platinum131KG2	Base131KP2	Silver131KP2	Gold131KP2	Platinum131KP2	Base121KD2	Silver121KD2	Gold121KD2	Platinum121KD2
131KG	•	•	•	•								
	•	•	•	•								
	•	•	•	•								
	•	•	•	•								
	•	•	•	•								
	•	•	•	•								
	•	•	•	•								
	•	•	•	•								
	•	•	•	•								
	•	•	•	•								
	•	•	•	•								
	•	•	•	•								
	•	•	•	•								
131KP	•	•	•	•								
	•	•	•	•								
	•	•	•	•								
	•	•	•	•								
	•	•	•	•								
	•	•	•	•								
	•	•	•	•								
	•	•	•	•								
	•	•	•	•								
	•	•	•	•								
	•	•	•	•								
	•	•	•	•								
	•	•	•	•								
121KD	•	•	•	•								
	•	•	•	•								
	•	•	•	•								
	•	•	•	•								
	•	•	•	•								
	•	•	•	•								
	•	•	•	•								
	•	•	•	•								
	•	•	•	•								
	•	•	•	•								
	•	•	•	•								
	•	•	•	•								
	•	•	•	•								



Proudly Made in the USA

5-TON A.C. MPU



Quality Trailer Construction:

- Heavy-duty welded frame
- Powder-coated, galvanized steel panels.
- Stainless steel hardware
- Trailer is load balanced
- Mobile climate control providing ventilation & de-humidification



*Built to handle the daily
hostile environment of
underground utility work!*



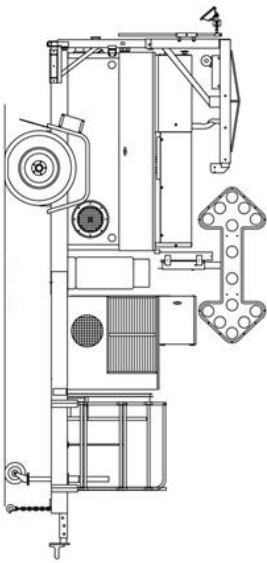

5-Ton MPU Series Options

- All Trailers Include:**
- Control Box
 - 3" Lunette Eye
 - Taillight Connector
 - 5/16"X34" Safety Chains with Hooks
 - Landing Jack with Steel Wheel
 - Rubber Wheel Chocks
 - Interior Compartment Light
 - Safety Tape Package
 - Safety Cone Storage
 - 5-Ton Air Conditioner
 - Blower Hose 8"X25'
 - Electric Brakes

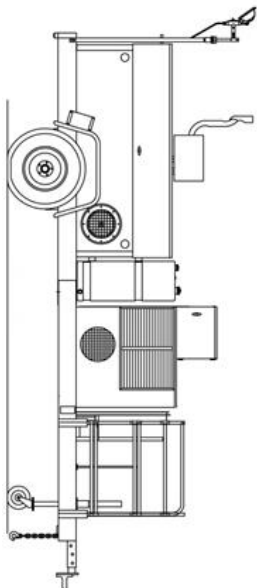

UNIT MODEL	5-Ton MPU				POWER
	1511D	151HP	151KG	5-Ton MPU	
					POWER
					15kW Generator--Gas
					15kW Generator--Propane
					15kW Generator--Diesel
					30 Amp Standby Power Cord
					100 Amp Pin & Sleeve Receptacle (60 Amp Capacity)
					DC Accessory Outlet on Control Panel
					Additional GFI Receptacle on Control Box
					30' Power Cord Reel with 3 Receptacles
					Solar Battery Charger
					RUNNING GEAR
					Standard Incandescent Trailer Lights
					LED Taillights
					SAFETY AND WORK LIGHTING
					Adjustable Light Standard--Curb Side
					Adjustable Light Standard--Street Side
					500 Watt Floodlight
					(2) Dual Floodlights (2- 500 Watt)
					Inside Storage for Light Accessories
					Flasher System for Taillights
					Front-Mounted Arrowboard Assembly
					VENTILATION
					2-Speed Blower-No Heat
					2-Speed Blower with Hot Water Heat Exchanger
					6000 Watt Heat Boost
					9000 Watt Heat Boost
					COMPRESSED AIR & WATER PUMPING TOOLS
					Submersible Pump with Remote
					2" Centrifugal Pump
					3" Centrifugal Pump
					Discharge Hose 2" x 25'
					Single 1 1/2 hp Oil-Type Air Compressor
					Dual 1 hp Oil-Less Air System
					Air Hose Reel 1/4" x 25' for Tool Air System
					Air Hose Reel 1/4" x 25' for Dry Air System
					Tool Lubricator
					Heatless Dryer System 6" Towers
					Heatless Dryer System 12" Towers
					Audible Wet-Air Moisture Alarm
					ACCESSORIES
					Manhole Guardrail and Rim
					Spare Tire and Wheel With Bracket
					Fire Extinguisher
					Mud Flaps
					Jib Crane with Stabilizer
					Tripod Storage Box



7 X 12

Proudly Made in the USA



Quality Trailer Construction:

- **ALL-** aluminum, low weight construction provides cost-effective, eco-friendly durability and high payload capacity advantages.
- The roof on the Fiber Optic Splicing Lab is a single, seamless sheet of 18-gauge aluminum with beveled corners overlapping the side walls. The sheet is bonded to a system of formed aluminum trusses on a welded frame.
- Walls and ceiling are insulated with R-11 insulated wall board, providing a comfortable and clean environment
- Solid floor decking made from extruded aluminum
- Medium voltage wiring is enclosed in metallic conduit for safety in addition to providing for future expansion / maintenance requirements



*The proven line of fiber
optic splicing labs!*



6 X 10

Proudly Made in the USA



Quality Trailer Construction:

- **ALL-** aluminum, low weight construction provides cost-effective, eco-friendly durability and high payload capacity advantages.
- The roof on the Fiber Optic Splicing Lab is a single, seamless sheet of 18-gauge aluminum with beveled corners overlapping the side walls. The sheet is bonded to a system of formed aluminum trusses on a welded frame.
- Walls and ceiling are insulated with R-11 insulated wall board, providing a comfortable and clean environment
- Solid floor decking made from extruded aluminum
- Medium voltage wiring is enclosed in metallic conduit for safety in addition to providing for future expansion / maintenance requirements



*The proven line of fiber
optic splicing labs!*





6 X 8

Proudly Made in the USA



Quality Trailer Construction:

- **ALL-** aluminum, low weight construction provides cost-effective, eco-friendly durability and high payload capacity advantages.
- The roof on the Fiber Optic Splicing Lab is a single, seamless sheet of 18-gauge aluminum with beveled corners overlapping the side walls. The sheet is bonded to a system of formed aluminum trusses on a welded frame.
- Walls and ceiling are insulated with R-11 insulated wall board, providing a comfortable and clean environment
- Solid floor decking made from extruded aluminum
- Medium voltage wiring is enclosed in metallic conduit for safety in addition to providing for future expansion / maintenance requirements



*The proven line of fiber
optic splicing labs!*



All Trailers Include:

- 5.5 kW Generator
- Custom cabinets with organizational drawers & bins
- Abundant lights and electrical outlets
- 9,200 BTU roof mounted air conditioning unit
- Heavy-duty rubber floor mat
- Carbon monoxide alarm
- R-11 Insulation
- DOT LED lighting package
- 3,500 lb axle
- Power converter
- 20 gallon fuel cell
- All aluminum frame, floor, walls & roof
- Strobe Light
- Large tinted window
- Ship to shore power connection

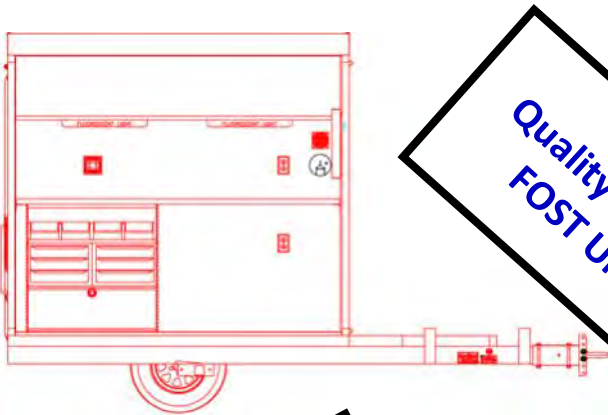

**SAME
Quality of Larger
FOST Units!**

**LESS
Fuel
Consumption!**

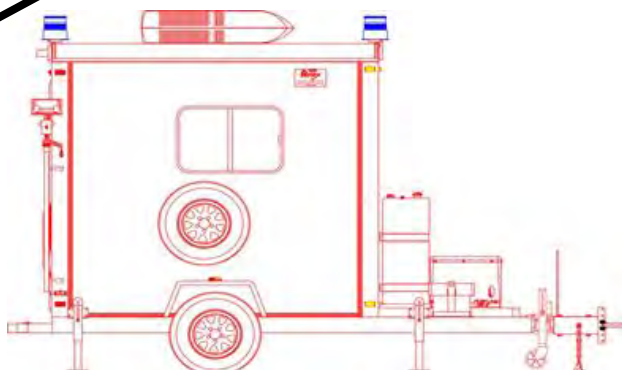

UNIT MODEL	CUB-6' X 8"	 A Division of Synergy Power Group, LLC CUB Series FOST 6X8 Options
	Base CG4 Platinum CG4	
		CONSTRUCTION
•	•	All-Aluminum Frame with Insulated Walls
•	•	Chrome Handles
•	•	20-Gallon Gas Tank with Non-Locking Gas Cap
•	•	4" X 12" Cable Entry Door
•	•	Damage-Resistant Folding Bumper
•	•	Window
•	•	Locking Gas Cap
•	•	High Energy Efficiency Insulated Floor
		ELECTRICAL
•	•	Fluorescent Task Lights, Interior Outlets, and Dome Lights
•	•	550 cca Battery in Box
•	•	Air Conditioner
•	•	Wall Heater
•	•	Exhaust Fan
•	•	CO Detector
•	•	5.5kW Generator
•	•	Control Box
•	•	12V DC Accessory Outlet
		RUNNING GEAR
•	•	Adjustable 3" Lunette Eye
•	•	Leveling Kit
•	•	Sandshoe Jack
•	•	Swivel Leveling Jacks
•	•	Rubber Wheel Chocks
•	•	Reflective Safety Tape
•	•	Spare Tire and Wheel with Bracket
•	•	Additional Leveling Kit
•	•	Dual-Wheel Jack
		EXTERIOR LIGHTING AND SAFETY DEVICES
•	•	(2) Strobe Lights
•	•	(2) Adjustable Light Standards
•	•	(2) Floodlights
•	•	LED Arrowstick
•	•	Cone Storage Bracket
		INTERIOR WORKSPACE
•	•	Custom Fit, Chemical Resistant Flooring
•	•	Full-Length Countertop on Street Side
•	•	Aluminum Shelf on Street Side
•	•	Multi-Drawer Storage Module
•	•	3-Drawer Cabinet (40")- Street Side
•	•	H-Table (46")
•	•	4-Drawer Cabinet on Street Side (40")
•	•	(3) Overhead Cabinets
		ACCESSORIES
•	•	Fire Extinguisher
•	•	First Aid Kit
•	•	Clothes Hook
•	•	Mud Flaps

Fiber Optic Splicing Trucks

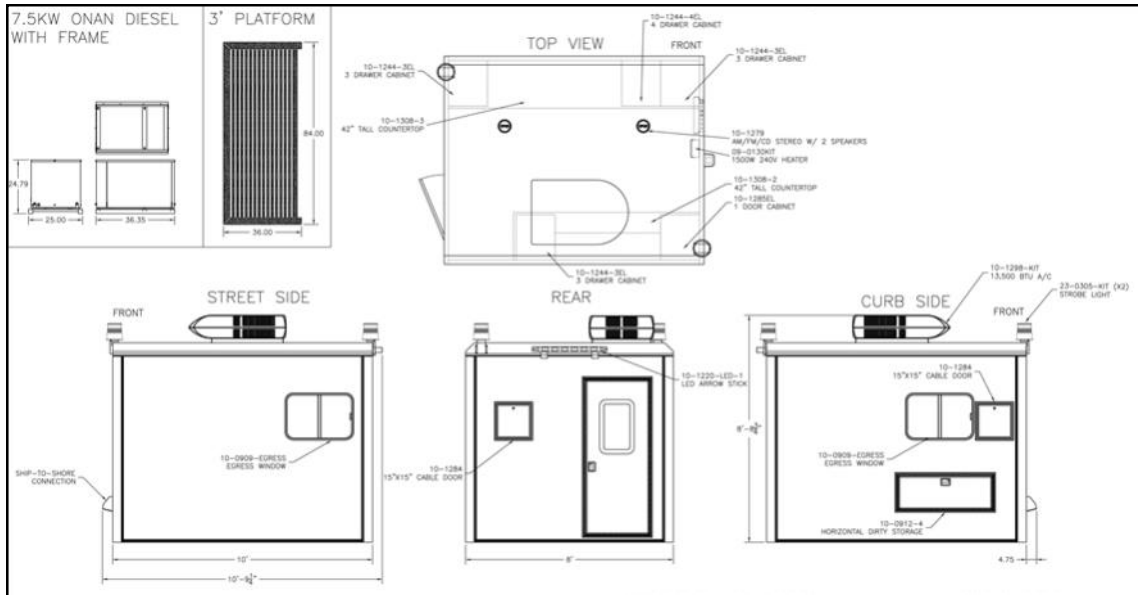

(standard layout shown)

8 X 10

Proudly Made in the USA



Same quality construction as our splicing trailers - now on a truck!

- Fully enclosed 8 foot by 10 foot box truck equipped for the splicing of fiber optic communications cable.
- The unit is fully self-contained and includes an electric power source, environmental controls, work surfaces, and equipment storage areas.
- The roof of the lab is a single, seamless sheet of 18 gauge aluminum with beveled corners overlapping the side walls. The sheet is bonded to a system of formed aluminum trusses on a welded frame.
- All power wiring is enclosed in metallic conduit for safety in addition to providing for future expansion / maintenance requirements.
- GFI protected circuits as well as all other circuits are split for load balance.
- A comprehensive list of optional equipment is available and can be installed during construction to accommodate all of your needs.

Ability to customize to the needs of the customer!

FEATURES

Fully enclosed 8' X 16' tandem axle trailer, equipped as a temporary satellite-based communications unit.

The unit includes an AC power generator, environmental controls, work surfaces and equipment storage areas.

SATCOM

Proudly Made in the USA



CONSTRUCTION

- All aluminum frame construction, including wall framing, roof trusses and undercarriage structural members.
- Dual torflex axles, rated at 5,000# each with electric brakes on both axles.
- Full rear ramp door, rated at 2,500#, with assist spring / cable assembly.
- Personnel door in front, curbside.
- Tinted emergency egress window on street side.
- Full length retractable awning on curb-side.
- Outside accessible street-side storage compartment.
- Enclosed AC generator compartment, front of trailer.
- Leveling jacks on all four corners.
- Adjustable pintle eye hitch
- Cone storage and wheel chock storage on front tongue.
- Roof access ladder, mounted on front of unit, with slip resistant treads.
- UNI-STRUT channel mounting for satellite dish.
- R-12 Insulation in the walls and ceiling.
- Dry-erase material on all interior wall surfaces.
- Slip resistant floor coating on solid floor surface.



ELECTRICAL / ELECTRONICS

- Electrical components protected by individual circuit breakers in main control panel.
- All power wiring in metallic conduit.
- All electrical boxes flush mounted for clean appearance.



DS - C

The POWERMASTER® Delivery System provides power distribution for positive air flow ventilation, heat, and any tool used in or around an enclosed environment. Unit is designed to be fork lifted into an enclosed truck body and powered with a genset option.

Special Features:

Blower 6000 Watt w/ Hot Water Heat
 25' Blower Hose w/ Storage
 30' 12 VDC Remote Control Reel
 30 Amp Standby Receptacle
 1.5 hp Oil Type Compressor
 20 Gal Air Receiver with Auto Drain

Regulator Panel
 Filter Panel
 Hose Reels (Tool & Dry)
 6" Heatless Dryer
 Moisture Alarm
 Manhole Rim Storage

Includes:

Control Box w/ Panel Light
 (2) 120 VAC, 20 Amp Spec Grade Duplex Outlets w/ GFI protection
 (1) 120 VAC, 20 Amp Spec Grade Outlet w/ 12 VDC Remote Capabilities
 (1) 240 VAC, 20 Amp Outlet w/ 12 VDC Remote Capabilities
 Individual Breaker Control of Components

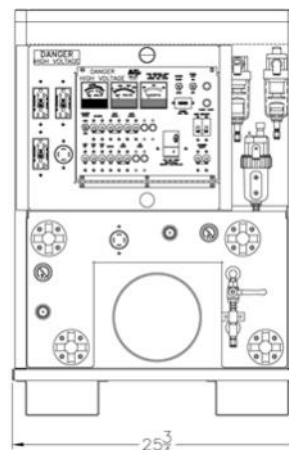
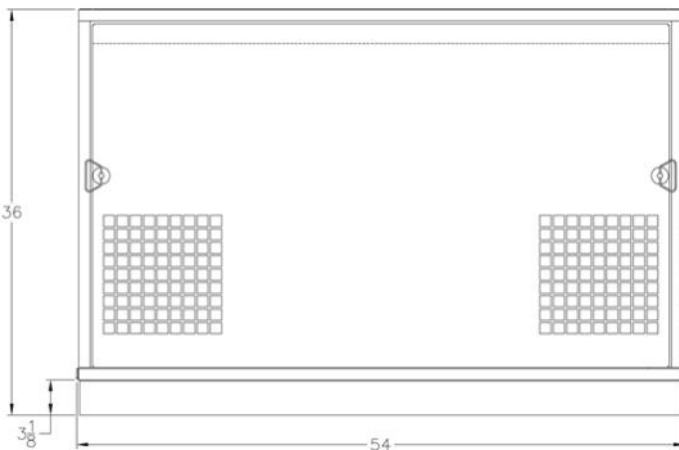

DS - AC

The POWERMASTER® Delivery System provides power distribution for positive air flow ventilation, heat, and any tool used in or around an enclosed environment. Unit is designed to be fork lifted into an enclosed truck body and powered with a genset option.

Special Features:

- Blower (No Heat), 2 Speed
- Air Conditioning 2-Ton 24,000 BTU
- 30' 12 VDC Remote Control Reel
- 30' Cord Reel 120 VAC w/ (3) Receptacles
- 25' Blower Hose w/o Storage

Includes:

- Control Box w/ Panel Light
- (2) 120 VAC, 20 Amp Spec Grade Duplex Outlets w/ GFI protection
- (1) 120 VAC, 20 Amp Spec Grade Outlet w/ 12 VDC Remote Capabilities
- (1) 240 VAC, 20 Amp Outlet w/ 12 VDC Remote Capabilities
- Individual Breaker Control of Components

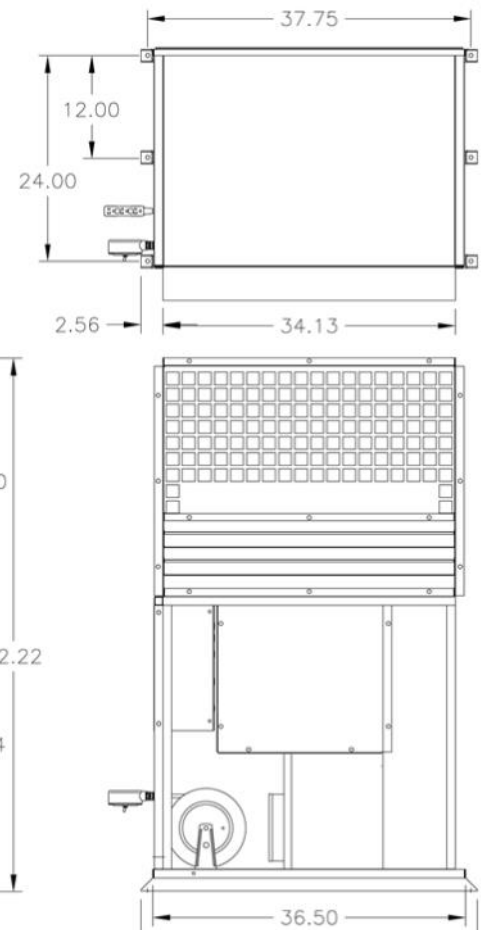
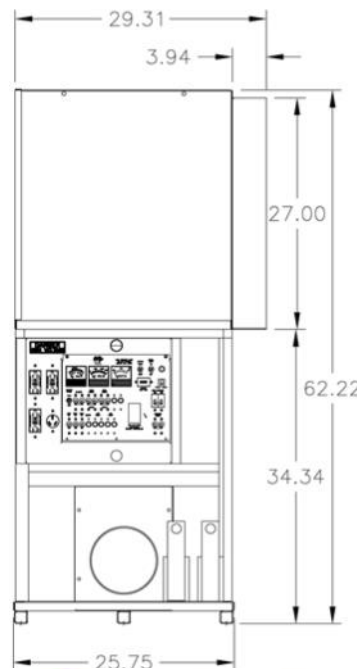

DS - AC/H

The POWERMMASTER® Delivery System provides power distribution for positive air flow ventilation, heat, and any tool used in or around an enclosed environment. Unit is designed to be fork lifted into an enclosed truck body and powered with a genset option.

Special Features:

- Blower 6000 Watt w/ Hot Water Radiator
- Air Conditioning 2-Ton 24,000 BTU
- 45' Retractable 12 VDC Remote Control Reel
- 25' Blower Hose w/ Storage
- 45' Retractable Cord Reel 120 VAC 10 Amp (4) 120 VAC Receptacles
- 45' Retractable Light Reel 120 VAC 10 Amp

Includes:

- Control Box w/ Panel Light
- (2) 120 VAC, 20 Amp Spec Grade Duplex Outlets w/ GFI protection
- (1) 120 VAC, 20 Amp Spec Grade Outlet w/ 12 VDC Remote Capabilities
- (1) 240 VAC, 20 Amp Outlet w/ 12 VDC Remote Capabilities
- Individual Breaker Control of Components

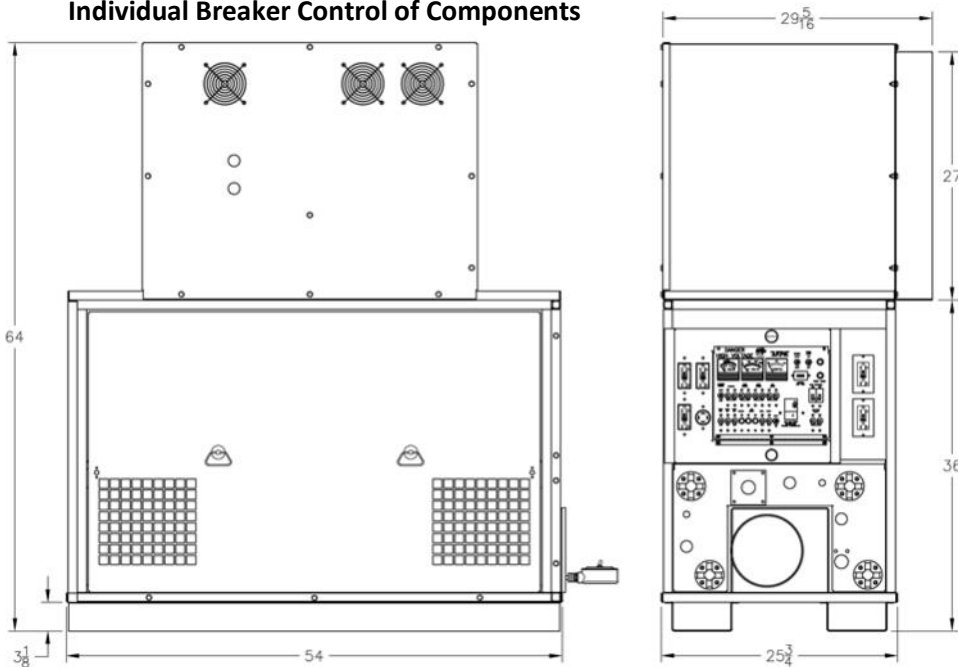

DS - GAS

Includes:

13kW Genset
120/240 VAC Single Phase
Hot Water Heat Circulating Capable
Heat Exchanger
Truck Mount with 50 Amp Breaker
Single Side Service Ability
Spin-On Oil Filter

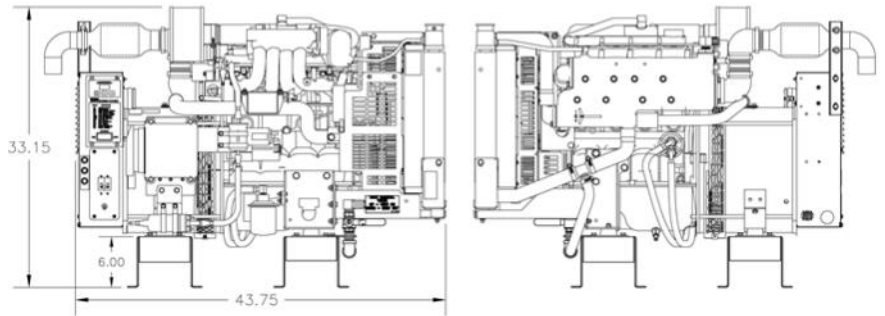

**Port Fuel Injected
Shutdown Safety Switches for:**

- Low Fuel
- Engine Overspeed
- High Engine Temperature
- Low Oil Pressure

DS - DIESEL

Includes:

12kW Genset
120/240 VAC Single Phase
Hot Water Heat Circulating Capable
Truck Mount with 50 Amp Breaker
Single Side Service Ability
Spin-On Filters

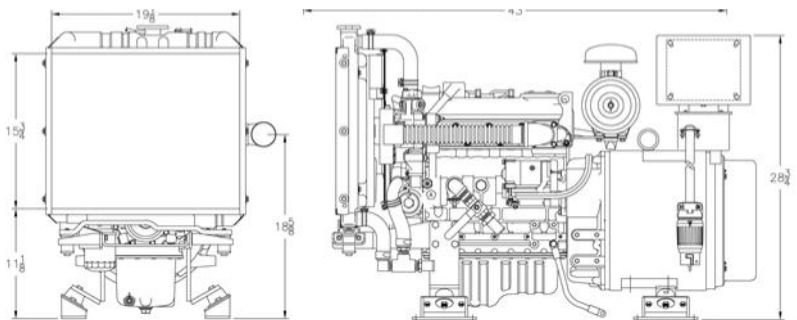

**Direct Injected
Shutdown Safety Switches for:**

- Low Fuel
- Engine Overspeed
- High Engine Temperature
- Low Oil Pressure



Proudly Made in the USA

The PLAT



This **TEAM FENEX** quality trailer offers:

- 16' long X 7' wide full aluminum manufactured trailer (frame, floor, interior/exterior wall sheeting, wall studs, one-piece seamless roof)
- Fully-integrated breathable air with endless SCBA refills, provides a mobile SCBA refill unit or stationary unit back at the fire station.
- Scene and work area lighting; NFPA ground lighting; LED DOT lighting
- Dual power source (onboard genset and ship-to-shore)
- Power tongue jack for ease of hook ups to tow vehicles
- 48 HP John Deere industrial engine (with block heater and 30kW brushless generator) offering a full 30kW of generator power, with resistive load banks for preventive maintenance and low amp draw loads.
- 45-gallon fuel cell
- **Ability to customize to the needs of the customer!**



**Cascade System - 6000 PSI,
D.O.T. /UN type, 10 year re-test cycle**
• (4) tank system 2036 CU. FT. Storage
(509 CU. FT. per)

Lighting

- (2) Integrated light towers, roof-mounted, remote controlled, dual 1500 watt lamps, 240 VAC
- (2) Tri-pod flood lights, with dual Magnafire 3000, 750 watt lamps, 120 VAC (Inside storage)

Control Area

- (1) Compressor, 5 CFM, 6000 PSI, Bauer open vertical air system
 - ☒ Fills 30-min cylinder in 8 minutes
 - ☒ Medical grade 67,000 CU. FT. purification system with SECURUS electronic cartridge monitor

Bauer Fill Station Class 2

- Front loading tilt out door
- Fills (2) SCBA cylinders and has (4) cascade controls w/ valves and gauges

For More Information:

Contact **TEAM FENEX**
1-800-88FENEX
SALES@TEAMFENEX.COM





15 & 25 Light Models Trailer Mounted Arrowboard



Proudly Made in the USA



15 & 25 LIGHT MODELS

Quality Trailer Construction:

- Heavy-Duty Frame
- Virtually Maintenance - Free Design
- Trailer Balance Weight Distribution for Towing & Un-hitched Positioning
- 60 Watt Solar Panels
- Quiet Operation - No Generator
- Four, 6-Volt Deep Cycle Batteries
- Battery Saver Shut-Down
- Integrated Solar Regulator
- Automatic Day/Night Mode



The Arrowboard Trailer designed specifically for the utility industry!

1-800-88FENEX



www.teamfenex.com

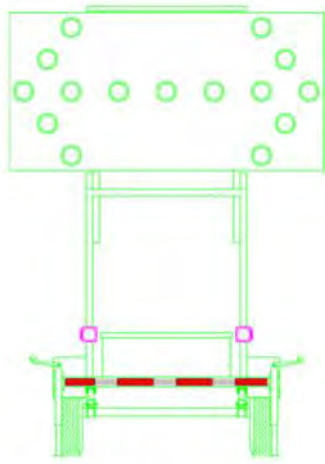

BASE TMAB15

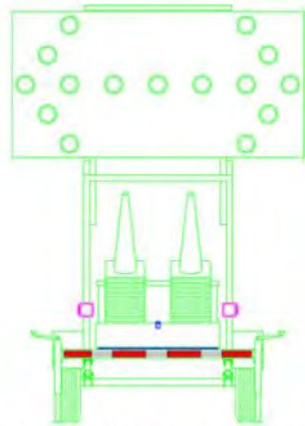

PLATINUM TMAB15

SOLAR ENERGY!

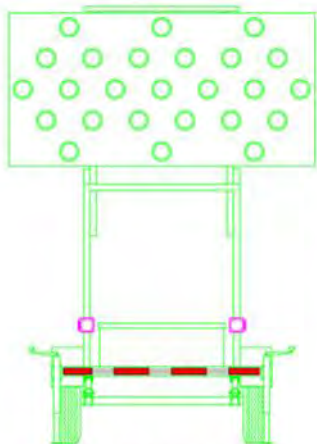

BASE TMAB25

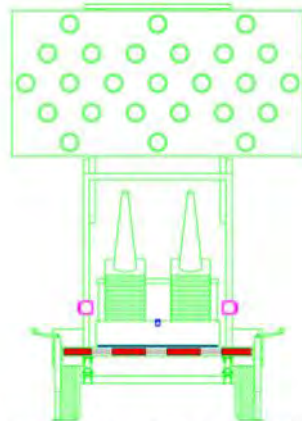

PLATINUM TMAB25

UNIT MODEL		TMABVA				 A Division of Synergy Power Group, LLC	Trailer Mounted Arrowboard Series Options
							CONSTRUCTION
							<input type="checkbox"/> Orange Color <input type="checkbox"/> 4' X 8' Arrowboard <input type="checkbox"/> EZ Lube Axle <input type="checkbox"/> Single Solar Panel <input type="checkbox"/> Dual Solar Panel
							RUNNING GEAR
							<input type="checkbox"/> Taillight Connector <input type="checkbox"/> Standard Incandescent Taillight <input type="checkbox"/> Reflective Safety Tape <input type="checkbox"/> Rubber Wheel Chocks <input type="checkbox"/> 3" Lunette Eye <input type="checkbox"/> Safety Chains <input type="checkbox"/> Electric Brakes <input type="checkbox"/> LED Taillights
							ACCESSORIES
							<input type="checkbox"/> Storage Box for Roll-Up Signs <input type="checkbox"/> Safety Cone Storage <input type="checkbox"/> Battery Charger with Cord Reel <input type="checkbox"/> Battery Condition Indicator <input type="checkbox"/> Visual Backup Locators

10 kW - 18 kW

Proudly Made in the USA



Construction and Towing

- National School Bus Yellow
- 2000 lb Idler Axle (no brakes)
- 2½" Lunette Eye
- 15" Tires
- 5/16" X 36" Safety Chains
- Landing Jack, Fold-Up Style with Wheel
- 4-Prong Cole Hersee Taillight Connector
- Rubber Wheel Chocks with Storage
- Solar Panel

Electrical

- 4 CYL Diesel Engine
- 10kW 1 Phase, 120/240VAC Generator
- 42-gallon fuel tank
- Control Box
- 100 Amp receptacle
- 25' Extensions Cord
- 25' 30 Amp Standby Power Cord
- Breaker Panel with:
 - (1) 25 Amp Breaker
 - (1) 30 Amp Breaker
 - (1) 40 Amp Breaker
 - (1) 120 V GFI Duplex Receptacle

Standard Features:

- Control Panel
- 60Hz, 120/240 VAC
- 120V Receptacle
- Powder-Coated Body Panels
- Galvannealed Steel Construction

Selected Options:

- Available in 3-phase
- Available in Gasoline
- Custom Power Connections, Available in 30 & 100 Amp
- Extension Cord
- Digital Controller



25 kW - 100 kW

Proudly Made in the USA



Construction and Towing

National School Bus Yellow
3500 lb Idler Axle with Electric Brakes
2½" Lunette Eye
15" Tires
5/16" X 54" Safety Chains with Safety Hooks
Landing Jack with 36" Steel Wheel
6-Lead Cole Hersee Taillight Connector
Rubber Wheel Chocks with chain and storage
Fork Pockets

Electrical

4 CYL Diesel Engine
25KW 1 Phase 120/240 VAC Generator
100-Gallon Fuel Tank
Control Box
100 Amp Receptacle
25' Extensions Cord (pin and sleeve ends)
Breaker Panel with:
(4) 15 Amp Breakers
(1) 30 Amp Breaker
(1) 100 Amp Breaker

Standard Features:

- 25kW Continuous Power or 30kW Standby Power
- 100 Amp Main Breaker
- Digital Control Panel with Automatic Shutdowns
- Galvannealed Steel Construction
- 11 Gauge Frame, 16 Gauge Lid and Doors
- Four Lifting Points for Hoisting
- 100-Gallon Molded Cross-link Polyethylene Fuel Tank
- Over 80 Hours Run Time @ 50% Load, with Full Fuel Tank
- Extension Cord

Selected Options:

- Available in 3-phase
- Electric Brakes



Mobile Transformer Trailer



GENERAL DESCRIPTION

The TEAM FENEX Mobile Transformer Trailer (FIGURE 1) is designed to carry an electrical power transformer and be used for an increased electrical load situation or for temporary replacement of a damaged transformer. The trailer is capable of housing single phase transformers rated at 75, 100 and 167 kVA. The trailer is designed to provide a secure enclosure for all of the mechanical and electrical components and permit fully protected operation with all access covers closed. The trailer compartments are able to be key locked while in the closed position (FIGURE 2).

The transformer compartment is provided with ventilation on the top and bottom of the trailer for heat dissipation.

TRAILER FRAME AND BODY SPECIFICATIONS

The trailer frame is fabricated of formed 1/4" steel. The front, rear, side panels, and doors are fabricated of galvanized sheet metal to prevent rust. The trailer is primed and painted white by powder coating. The trailer tongue is an A-Frame design. The welded part of the frame assembly, with a swing-up adjustable dolly wheel, is rated for tongue weight plus 50%. (*Trailer tongue weight does not exceed 15% of actual trailer weight.*) Adjustable frame corner jacks are installed for stabilization. All access doors are lockable and all are keyed alike. All hardware, i.e. nuts, bolts, washers, latches, hinges, etc., are made of stainless steel where applicable. The trailer is designed to house two sets of wheel chocks. The trailer is designed to store one T-Handled screw type ground rod (FIGURE 2).



TRAILER FRAME AND BODY WEIGHTS AND DIMENSIONS

- Overall length: 134"
- Overall width: 72"
- Trailer height: 68"
- Trailer weight: approx. 4000 Lbs. (167kva)

TRAILER BRAKES AND RUNNING GEAR

Trailer comes standard with a hydraulic surge brake rated with a 2 X safety factor. Safety chains are 3/8" x 48", with safety hooks. The single axle is an E-Z lube design, with a capacity of 6000 Lbs. Hubs are a (6) lug pattern on 5.5" centers. Springs (2) are 4-leaf and have a capacity of 2400 Lbs each. Wheels are 15" standard. Tires are ST225/75R15 load range D with a load rating of 2540 Lbs @ 65psi. Drawbar is a 3" pintle eye (tongue hitch) and adjustable from 12" to 24".

TRAILER LIGHTING SYSTEM

The trailer is equipped with stop, turn, run, and side marker lamps. Marker lights: two each amber side marker lights (street & curb), two each red marker lights (front and rear). Stop, turn, and run lights, are located at the rear of the trailer. All lights are securely attached and protected as necessary to prevent damage under normal operating conditions. Six inch (6") amber warning lights are placed at all four corners of the trailer for visibility and shall be designed to operate on 120 VAC from the transformer, when energized. A dedicated and lockable battery storage drawer is provided on the rear street-side corner. The battery is protected from discharge by an integral battery charger.



WIRING STORAGE REELS AND COMPARTMENT

The trailer includes covered and lockable storage reels for six 4/0 CU 600V x 100ft., and two #2 CU 15 KV x 100 ft. cables. A unique design for the reel rack allows each reel to pay out or in independently, or in unison with the other reels, as the shaft is turned by the provided crank.

Note: Product shown includes some customer supplied equipment.

Disaster Relief Trailer



D.R.T.

Proudly Made in the USA



*This **TEAM FENEX** manufactured fully enclosed 7 X 12 trailer has the ability to work in many disaster relief capacities including the following:*

- Ability to cool a tent or structure
- Provide relief (cooling, heating, ventilation) to emergency workers
- Provide a climate controlled area for volunteers during a disaster
- Provide scene lighting
- Interior storage capabilities
- Ability to provide stand-by power to 60 amps
- Compressed air system for use in emergency scene activities
- 2,000 pound cargo capacity



Disaster Relief Trailer



- The trailer is manufactured primarily from aluminum which includes frame, floor, walls, roof rafters, one piece seamless roof, and inner/outer skin.
- Interior storage is provided by three overhead cabinets, independent locking, gas shocks for doors, powder coated white.
- Trailer incorporates a 2 HP compressor system capable of 125 psi @ 11 CFM which includes a 20 gallon air tank with automatic and manual drains, 25 foot retractable hose reel, 50 foot of hose extensions, gauge and regulator.

- Air conditioning is provided via a 5 ton 60,000 BTU system with return air (1200 CFM, 33 degree drop from wet ball). The unit incorporates (4) four 25 foot insulated blower hoses (w/storage) that can get the unit 50 foot from the area to be cooled, heated, or ventilated.
- Heat is provided by the engine coolant system which circulates through a secondary radiator. Heat boosts are also in line (12,000 watts) to provide a rise of 50 degrees @ 800 CFM at the end of the blower hose.
- Ventilation is also provided at 1200 CFM with no heat or cooling.



- The systems on-board are powered by a 15 KW diesel genset (120/240VAC, 60 amps) Dual 20 gallon fuel cells provide run times that exceed 40 hours.
- Power distribution is provided through a load/control center. The load/control center is located street side interior near the rear door convenient to the primary work area. A 100 amp pin and sleeve receptacle is provided for stand-by use as well as (3) three, control mounted 120 VAC GFI receptacles.

Air Reclamation Trailer

FEATURES

- On board 50 amp generator powering 120 VAC and 240 VAC outlets
- High pressure (tool) system adjustable from 0-125 PSI
- Low pressure (dry air) system with adjustable regulator
- 42 gallon diesel fuel tank providing more than 24 hours continuous run time
- Secure, weather tight enclosure
- Centralized control panel located curb side
- All access panels are lockable and keyed alike



Air Reclamation

SPECIFICATIONS

- Output Capacity 25,000 SCFD
- Engine / Generator 12.5kw continuous, 120/240 VAC, single phase, 60 Hz
- Fuel Tank 42 gallon, certified, polyethylene
- Run Time (% of load / hours)
 - 25% / 63
 - 50% / 49
 - 75% / 37
 - 100% / 28
- Electrical Outlets
 - (2) 120 VAC, 20 amp, duplex, GFI
 - (1) 240 VAC, 30 amp, GFI
- Outlet Pressure Range 0 - 25 PSIG (adjustable)
- Outlet Air RH less than 2% RH
- Compressor Type (3) Oil-less, 2 HP
- Axle E-Z lube, 3,500 lbs capacity
- Springs (4) Leaf, 2400 lbs capacity each
- Wheels / Tires 15" mod. rims / P215/75R15
- Trailer Lighting Side Markers -
- Stop, Turn, and Run Lights at rear
- Dimensions 120" L x 68" W x 88" H
- Net Weight 2750 lbs



ACCESSORIES & OPTIONS

- Telescopic Work Lights
- Flow Gauge
- Humidity Alarm
- Retractable Hose Reel
- Power Extension Cords
- Electric Brakes w/ DOT Breakaway System

John Deere Power

Engine power packs are available with several different hp settings and configurations to drive pto's, water pumps, car crushers, irrigation, transmissions, etc. These engines can be configured to our standard analog control boxes or our optional digital display panel.



JOHN DEERE

**Let us built your next
Power Units**

**We can customize to
your needs**





JOHN DEERE



Standard Options

Oil & Water site level gauges with optional safety shutdown feature

Digital or Analog display controllers

Skids designed to be set in fields as stand alone or bolted down to either concrete pads or trailer beds

Installed PTO's made to handle all size horsepower and applications

Optional size transmissions available to handle the horsepower

Optional water pumps or trash pumps light duty to extreme heavy duty

Optional hydraulic pumps

Optional air compressor can be installed into the standard SAE flange auxiliary drive if equipped

Not listed?
No Problem just ask us

Proven performance above and below the ground John Deere and TEAM FENEX products are built to handle tough, off-highway applications, no matter what the task.



JOHN DEERE

Parts & Accessories



MANHOLE RIMS



**MANHOLE
GUARDRAILS**

**HUBBELL
CONNECTS**



SAFETY LIGHTING



**CENTRIFUGAL
PUMPS**



**DEWATERING
PUMPS**

AND MANY MORE...



ISO CERTIFIED

A Division of
Synergy Power Group, LLC

Centrifugal Pump

MODEL # 10-1111

HP	VAC	AMPS	LENGTH	WIDTH	HEIGHT	GPM	WEIGHT
5	220	19.5	28"	11"	26"	280	-

Tough, high-capacity pumps that move high volumes of water, so your crew can get to the work that needs to be done. These pumps work, and they keep on working; with rugged, durable construction that can stand up to just about anything.

features:

- Cast iron pump housing permanently mounted to rigid steel base
- Balanced and trimmed impeller to prevent overload
- Self-priming pump direct coupled to motor
- Factory sealed bearings for lower maintenance cost
- Call for 2 HP , 220 VAC information



12 VDC Powered Submersible Pump

MODEL # 10-0460

VDC	HP	VDC	AMPS	LENGTH	WIDTH	HEIGHT	GPM	WEIGHT
12	1.3	12	30	-	7"	20"	43	33 lbs.

features:

- Easily portable, operates on any 12 volt or automatic battery
- Remote waterproof controller integrated into the pump cable for safe operation
- Impeller with topside repelling vanes keep grit and grime away from the steel shaft
- Watertight o-ring seal keep pumps internals dry
- Self-lubricating shaft seal



1.1 HP Submersible Pump

MODEL # 10-0158F

VAC	HP	AMPS	LENGTH	WIDTH	HEIGHT	GPM	WEIGHT
110	1.1	9.8	50' Cord	7.3"	17"	90	27.5 lbs.

Designed and built by FLYGT Corporation to Team Fenex's demanding specifications, this submersible pump can handle a wide range of operating conditions.

features:

- Can handle abrasive & corrosive liquids
- Seals and motors engineered to handle a wide range of operating conditions including partial submergence, snoring and dry running
- CSA tested and approved to UL standard for safety #778
- Independent inner and outer mechanical seal sets with an oil chamber for isolation, cooling and lubrication



2.0 HP Submersible Pump

MODEL # 10-0345STAN

VAC	HP	AMPS	LENGTH	WIDTH	HEIGHT	GPM	WEIGHT
230	2.0	10	50' Cord	8.75"	18"	135	57 lbs.

STANCOR™ pump technology & design

features:

- Double stainless steel casing
- Double mechanical seals run in a separate oil filled compartment, outboard lip seal helps prevent solids from infiltrating primary sealing unit
- Cast iron diffuser with rubber line, prevents wear on the diffuser
- Hardened cast iron impeller for extended life usage



Aluminum Anti-Sludge Pump Stand

MODEL # call for details

Team Fenex innovation; designed to raise pump above sludge level, available for different Team Fenex pumps.

features:

- Anti-sludge adjustable pump stand
- Aluminum construction
- Lightweight and durable

Got Questions?

Call the Team Fenex Customer
Service Team for Product &
Maintenance Questions !

1.800.88.FENEX



2" & 3" Strainer Assembly

MODEL # 10-0341 – 3"

MODEL # 10-0340 – 2"

features:

- Eliminate unnecessary repairs by keeping debris and particles out of the pump
- Easy disassemble, cleaning, and reassembly
- Quick Connect to suction hose
- Available in 2" quick connect & 3" connect



Discharge Hose Options

MODEL# call for details

features:

- 2" & 3" option & many combinations available
- Collapsible hose
- 2 quick-connect couplers
- Custom discharge hose lengths available



Suction Hose

MODEL # call for details

features:

- 2" & 3" option & many combinations available
- Non-collapsible hose
- 2 quick connect couplers
- Wire reinforced, flexible even in cold water



Got Big Plans?

Call the Team Fenex Sales Team to
Custom Build a Product that Fits Your
Utility & Safety Needs!

1.800.88.FENEX

Steel Manhole Guard Rail

MODEL # 10-0001

features:

- Lightweight: 38 lbs.
- Non-corrosive tubular steel
- Durable, powder coated safety yellow
- Heavy-duty construction
- Compact for easy storage
- Quick and easy setup
- Provides protection for open manhole



Manhole Safety Ring

MODEL # 10-0166Y

features:

- Heavy duty aluminum construction
- Lightweight non-corrosive
- Painted safety yellow
- Fits standard 27" and 30" Manholes
- Standard 10" height rim
- Stackable & compact for easy storage
- Multiple diameters available (See Below)



MODEL	HEIGHT	SIZE	WEIGHT
CUSTOM (CALL)	8"	27" X 30"	16 lbs.
10-0166Y	10"	27" X 30"	18 lbs.
CUSTOM (CALL)	12"	27" X 30"	20 lbs.

Aluminum Extension Planks

MODEL # 10-0024

features:

- Extension plank extends from a stored position of 48" to an extended length of 72"
- 12" wide and 2" thick
- Lightweight: 19 lbs.
- Quick-release spring latch on side of board allows you to set board at a desired length
- Strong durable aluminum construction



Fiber Optic Splicing Truck

Designed by fiber optic splicing technicians & outfitted for YOUR preferred truck body. The Fiber Optic Splicing Truck has all the same features as the Team Fenex leading Fiber Optic Splicing Trailer product line. Maximize storage while improving YOUR work area safety and productivity.

Wooden Extension Planks

MODEL # 10-0023

features:

- Extension plank extends from a stored position of 48" to an extended length of 72"
- 12" wide and 2" thick
- Lightweight: 23 lbs.
- Convenient opening and closing
- Strong durable construction
- One man duty rating 250 lbs.



Manhole Platform Support

MODEL # 10-0004

features:

- Support extension planks to form a sturdy working platform
- Extends from a stored length of 33" to fully extended length of 73"
- Reinforced aluminum construction
(steel available)
- Lightweight: 19 lbs.
- Spring-actuated latch for locking in cable rack



Steel A-Frame Gantry Material Lift

MODEL # 10-1250-1

features:

- Sets on a standard manhole guard
- Constructed from steel square tubing for increased strength without the weight
- The A-frame folds down to 6 1/4" wide x 6 3/4" tall x 41 1/4" long when not in use



**Do We Not Have What You're
Looking For?**

Let the Team Fenex Customer Service
Team Find What You Need!

1.800.88.FENEX

Floodlight & Strobe Assembly

MODEL # 10-0451N

features:

- Floodlights 110 VAC quartz-halogen
- Rotating strobe beacon
- Flood adjust up and down
- 12' coil cord and grounded plug
- Weather-tight switchable flood light
- Custom models also available



Magnetic Base Quartz Floodlight

MODEL # 10-0035

features:

- Magnetic base
- 500 Watts output at 4.35 amps
- Adjustable lamp angle
- 12' flexible coil cord and grounded plug
- Plugs into a standard 115 volt outlet
- Weather tight switchable flood light
- Optional high-impact carrying case



Fiber Optic Splicing Trailer

Designed by fiber optic splicing technicians, this trailer protects workers from mother nature's worst. Equipped with all your needs for splicing efficiency.

Dual Floodlight & Strobe Assembly

MODEL # 10-0255N

features:

- 500 Watts , 110 VAC dual floodlight
- Rotating strobe beacon
- Flood light adjusts up and down
- 12' coil cord and grounded plug
- Weather tight switchable flood light
- Custom models also available



Light Standard Assembly & Floodlight

MODEL # 10-0144 light standard

MODEL # 10-0453 flood light

features:

- 500 Watts, 110 VAC floodlight
- Adjustable light standard assembly
- Designed for use with Team Fenex Mobile Power Unit and Fiber Optic Splicing Trailer



Fiber Optic Splicing Trailer

Team Fenex Fiber Optic Splicing Trailers are constructed of an all Aluminum and custom built frame, as sturdy as it gets.

HUBBELL™ Connects

MODEL # call for details

Team Fenex can custom build any HUBBELL™ connects; length & amperage cable specified.



Wiring Device-Kellems



30 Amp, 25' ft. long Extension
Cord & Twist Lock

Model #: 10-1048



100 Amp x 100 Amp, 36" long
Adapter Cord

Model #: 10-P12W-C9W-36



200 Amp x 100 Amp, 26"
long Adapter Cord

Model #: 10-1057



100 Amp x 30 Amp, 36"
long Adapter Cord

Model # 23-0265



30 Amp x 30 Amp, 25'
long Adapter Cord

Model #: 10-1048



100 Amp x 30 Amp, 36"
long Adapter Cord

Model #: 10-1050



100 Amp
Pin & Sleeve
Receptacle

Model #: 04-0261



30 Amp
Pin & Sleeve Re-
ceptacle

Model #:04-0340

WARNER™ Trailer Lighting Cord

MODEL # 10-0103

Provides power to towing vessel for DOT lights and electric brakes.

features:

- 6-prong adapter
- Call for cord length options



Jib Crane Control Cord

MODEL # 10-0218

12 VDC control cord for the 10-1062LS Jib Crane option for the Team Fenex Mobile Power Unit and the Manhole Support Trailer.



Delivery System with Air Conditioning

A truck-mounted ventilation air and electrical power delivery system with an integral air conditioning option. Designed for convenient installation in utility truck applications, it can be applied as either stand alone or with an on-board generator package. Options can be added such as a dewatering submersible pump, lighting, remotes, and other accessories.

Remote Control Cord Reel

MODEL # 10-0091

features:

- Operates 12 VDC relay system to turn on 120/240 VAC submersible or centrifugal pump
- Safe: 12 VDC engages pump, and reel eliminates tangled cords in work area
- Eliminates climbing out of man hole to start and stop pump
- 16-gauge, 3-conductor, 25' ft. wire
- Retractable with positive latch mechanism to maintain working length
- Waterproof switch box
- 3-1/2" w X 13" h. X 10" d.
- 7 lbs. weight



**When You Buy
TEAM FENEX**

**You are buying
Industrial Quality**

**As a Dealer why would
you settle for less?**

Moisture Alarm

MODEL # 05-0001

features:

- Prevents moist air from entering system
- Visual and audible alarms at 10% humidity
- Works at pressure up to 30 psi
- Adapts to existing units
- Moist air by-pass
- 115 VAC, 1 phase, 60 Hz
- 6 1/4" width x 8 1/4" height x 3 3/4" depth
- 8 1/2 lbs.



Heatless Air Dryer

MODEL # 05-0002 (6")

MODEL # 05-0095 (12")

MODEL # 05-0096 (20")

features:

- Dries air at a wide range of temperatures and pressures up to 100 psi
- No need to replace expensive desiccant
- Eliminates need to carry bulky nitrogen tanks
- 8" width x 11" height x 5" depth
- 6", 12" and 20" towers available
- Lightweight 8 lbs.



Always call Team Fenex Customer Service for all your parts and Accessories needs!



features:

- Eliminates the danger of tangled cords
Retractable with positive latch mechanism to maintain working length
- Heavy-duty with tough corrosion and abrasion-resistant finish
- 3-1/2" w. X 13" h. X 10" d.
- Weight: 7 lbs.
- 1/4" hose with quick-connect
- 24' hose length



Oil-less Air Compressor

MODEL # 05-0038

Hz	HP	VOLTS	AMPS	LENGTH	WIDTH	HEIGHT	CFM	WEIGHT
60	1.0 & 3/4	115/230	14.8	17 5/8"	12 1/4"	8 15/16"	3.3	60 lbs.

Oil-less piston-type compressors that have a rugged construction and long service-free life span.

features:

- Corrosion Resistant
- 125 psi @ 5.5 CFM (1.0 HP Model)
- 125 psi @ 3.5 CFM (3.4 HP Model)



Belt-Driven Air Compressor

MODEL # 05-0080

Hz	HP	VOLTS	AMPS	LENGTH	WIDTH	HEIGHT	CFM	WEIGHT
60	1.5	115/230VAC	10	11"	13"	25.5"	5.0	150 lbs.

Single-stage oil lubricated belt driven air compressor.

features:

- Solid cast iron cylinder and crank case
- Aluminum head
- Stainless steel valves
- Mounted pressure switch with head pressure relief
- 3450 RPM



Mobile Power Unit Control Panel

MODEL # call for details

Control Panel that can be outfitted to any Team Fenex MPU (Mobile Power Unit). The control panel controls all electric equipment on-board the manhole support trailer.

features:

- 12 VDC/220 VAC/120 VAC
- 50 amp main breaker
- Battery charge indicator
- Individual breaker components
- Three (3) 120 VAC GFI protection receptacles
- Hour meter
- Start/Stop Control switch
- Volt, amp, and Hertz meter



Delivery System Control Panel

MODEL # call for details

Control Panel that can be outfitted to any Team Fenex delivery system with 50 amp, 240 VAC requirement.

features:

- 12 VDC
- Main breaker
- Individual breaker
- amp gauge
- Volt meter
- Battery voltage meter



Stand-by Generator Control Panel

MODEL # call for details

Manufactured to control a 100 amp genset, 25' hand-wired 30 amp pin and sleeve connector.

features:

- Digital display screen with multiple options
- 100 Amp/ 240 VAC main breaker
- 240 VAC, 30 amp, double pole breaker
- 120 VAC, GFI protected, receptacle breaker
- Emergency stop button
- Load center breakers



Fiber Optic Splice Trailer Control Panel

MODEL # call for details

Control Panel that can be outfitted to any Team Fenex Fiber Optic Splicing Trailer.

features:

- 30 amp main breaker
- 20 amp 2 pole, 220 VAC breaker
- 12.5 amp power converter with individual fuses
- Up to seven (7) 120 VAC circuits
- Display hour meter
- Dual 120 VAC, GFI protected receptacles



Mobile Power Unit

Designed to support manhole workers in the harsh environment the inner earth dishes up. The unit is equipped to ventilate, heat & air condition, and provide dry/tool air support in the manhole.

Diesel Engine Start/Stop Control Panel

MODEL # call for details

features:

- Push button start/stop
- Glow plugs push-button
- Fault shut down light
- Can start a John Deere, Isuzu, or Kubota



Fiber Optic Splicing Trailer

Provides ample room for a controlled splicing environment and plenty of storage for all your fiber optic supplies.

Gasoline Engine Start/Stop Control Panel

MODEL # 06-0570-1K

features:

- Push button start-stop
- Display hour meter
- DC voltage gauge
- Service engine light
- Can start a Kohler & Nissan engine



Propane Steel Tank

MODEL # 10-0086

features:

- 40 lb. steel tank
- Liquid or vapor withdrawal
- High-volume safety cut-off valve
- Full 12" diameter base for stability
- 60 lb. liquid or vapor withdrawal tanks available



Propane Aluminum Tank

MODEL # 10-0086A

features:

- 40 lb. aluminum tank
- Liquid or vapor withdrawal
- High-volume safety cut-off valve
- Full 12" diameter base for stability
- 60 lb. liquid or vapor withdrawal tanks available



The CUB

The new 6 x 8 Fiber Optic Splicing Trailer is designed to meet the needs of YOUR construction & utility crew. All the great features and quality of the original Team Fenex FOST in a more maneuverable and lighter size.

Propane Bottle Warmer

MODEL # 10-0033P

features:

- 110 VAC
- Strap type
- Resistive type heater
- Designed to be used on 40 lb. propane tank
- 6' power cord
- Thermostat controlled
- Hook & loop with spring type installation



Propane Hose & Valve Kit

MODEL # 07-0146

features:

- Fits any Team Fenex Mobile Power Unit
- Dual propane tank hose assembly



40 lb. Propane Tank Bracket Assembly

MODEL # 10-0231

Propane tank bracket assembly locks propane tank to the side of the Team Fenex trailers for safety and durability.

features:

- Designed for Team Fenex Mobile Power Unit and Fiber Optic Splicing Trailers, with propane engine
- Positive lock closure with safety snap



36" Stem with Wheel and Caster

MODEL # 23-0035 Gear Case

MODEL # 23-0050 Stem & Wheel

features:

- Designed for all Team Fenex Mobile Power Units
- 36" total height adjustment
- Gear case has integral grease fitting for fast lubrication
- Wheel is of a semi-pneumatic design and requires no air



Tongue Jack Dual Wheel Bolt On Style

MODEL # 30-0101-DW

features:

- 1,500 lbs. weight limit
- 10" lift
- Dual molded plastic wheels
- Integral grease fitting for ease of maintenance
- Designed for Team Fenex Fiber Optic Splicing Trailers



Solar Powered Arrowboard & Message Board Trailers

Designed specifically for the utility industry. Includes a speedy rig up and rig down design that handles the punishment of repeated daily use for traffic control at multiple locations.

Tongue Jack Single Wheel

MODEL # 07-5362

Designed for utility trailers, the tongue jack single wheel is a stable formed heavy-gauge steel construction for dependability.

features:

- Swing-away, bolt on application
- 1,500 lbs. weight limit
- 10" lift



ONLY at TEAM FENEX!

Proudly Made in the USA



Anti-theft Wheel Boot

MODEL # H-10/H-12

The Rhino™ H Series “Hook-Loc” anti-theft wheel boot features a one-piece welded steel construction, light in weight, and installs in 45 seconds.

features:

- Orange powder-coating provides high visibility and rust protection
- Telescoping dome assembly with protective beading prevents removal of wheel



6000 Watt Heater Element

MODEL # 09-0005

features:

- 240 VAC operation
- Thermostat protected
- 3,000 Watt or 6,000 Watt
- Resistive type heater
- Designed for use in Team Fenex Mobile Power Unit heat system



Brake Actuator

MODEL # 07-0007

features:

- Maximum weight 7,500 lbs.
- Hydraulic brake fluid system
- Adjustable flat plate
- Re-settable safety break away system
- Designed for Team Fenex Mobile Power Unit



Specialty Trailers

You dream it, we can help you build it! Team Fenex has assisted in multiple specialty builds over the years for unique needs. Call if your crew has a need for a specialty trailer.

2 1/2" Lunette Eye

MODEL # 07-0079

features:

- Drop forged 4-bolt mounted drawbar
- 2 1/2" I.D. eye
- Maximum vertical load, 7,000 lbs.
- 6" x 6" mounting plate
- Weight: 14 lbs.



3" Adjustable Lunette Eye

MODEL # 07-0077

Adjustable 3" lunette eye with a 14,000 lbs. gross vehicle weight.

features:

- 3" lunette eye
- 1 9/16" Inside height
- 5/8" Thru-bolt size, 2 bolts required
- 2 7/8" Inside channel width required
- 2,000 lbs. Max vertical capacity



Rubber Wheel Chock Assembly

MODEL # 10-0014

features:

- Tethered pair of rubber chocks
- Bolt-on holders available for all models



Ice Chock Steel Assembly

MODEL # 10-1039

features:

- Steel-plated ice chocks
- Bolt-on holders available for all models



Custom Truck Packages

The truck YOU design, using YOUR preferred service body PLUS Team Fenex's exceptional quality mobile power and delivery system equipment.

Safety Tow Chains

MODEL # 10-0227X (42")

MODEL # 10-0225 (36")

A must have for towing, the steel 36" and 42" safety chains serve as a cradle for all of the Team Fenex towing options.



Aluminum Fiber Optic Cable Clamp

MODEL # 10-0000

A Team Fenex innovation, the fiber optic cable clamp is designed to clamp fiber cable in place for splicing efficiency and accuracy.

features:

- Steel Cable Clamp available, call for details



Got Questions?

Call the Team Fenex Customer
Service Team for Product &
Maintenance Questions !

1.800.88.FENEX

BUY AMERICAN MADE!
QUALITY DOES MATTER!

Proudly Made in the USA



ISO Certified & NATM Certified



800.88FENEX

800.883.3639



For A Better Tomorrow!

Everything

your crews need for
safe, efficient utility
construction work...



800.88.FENEX

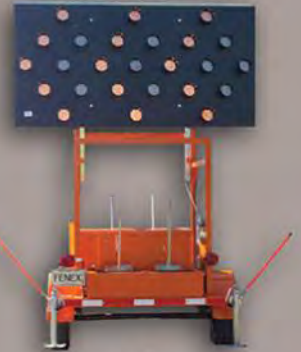

ArrowBoards



Fiber Optic
Splicing
Trailer



Truck Genset
Delivery System
Manhole Support



Accessories for Confined
Work Spaces



Standby Power
Generators
10 to 75KW



Mobile Air Conditioner Units
24,000 to 60,000 BTUs



50KW
Stand-by
Trailer



Manhole
Support
Trailers



MOBILE POWER & VENTILATION EQUIPMENT

610 Illinois Avenue, Sandoval, IL 62882 • Fax: 618.247.9055 • Email: sales@teamfenex.com ISO 9001-2000 Certified